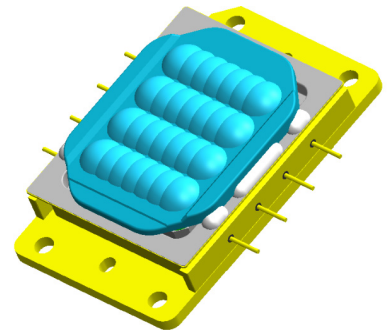

Laser Diode
Part No. NURM33-A
■ Features

- High Power Multiple Laser Diode (LD) Chip Package
- 28 Collimator Beams
- 7 series × 4 connection
- High Heat Dissipation

Standard Operating Conditions (CW Operation)

- Forward Current: 3.5A
- T_m=40°C, ACC (Auto Current Control) Operation

■ Absolute Maximum Ratings

Item	Symbol	Absolute Maximum Ratings	Unit
Forward Current	I _F	Table.1	A
Allowable Reverse Current	I _R	85	mA
Storage Temperature	T _{stg}	-40 ~ 85	°C
Operating Temperature (CW)	T _m	0 ~ 55	°C

Table.1 CW Operation

T _m (°C)	Rated Forward Current (A)	Absolute Maximum Forward Current (A)
0	2.65	2.90
10	2.75	3.00
20	2.90	3.15
25	3.00	3.25
30	3.15	3.40
35	3.30	3.55
40	3.50	3.75
45	3.25	3.50
50	2.60	2.85
55	1.85	2.10

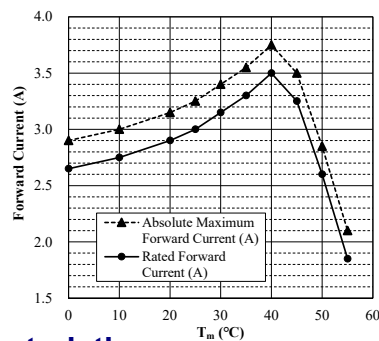
■ Initial Electrical/Optical Characteristics

 (T_m=25°C)

Item	Condition	Symbol	Min	Typ.	Max	Unit
Optical Output Power	I _F =3.0A CW	P _o	65	(72)	79	W
Dominant Wavelength ¹	I _F =3.0A CW	λ _d	635	(639) (643) (647)	651	nm
Threshold Current	CW	I _{th}	400	-	650	mA
Slope Efficiency	CW	η	-	(29)	-	W/A
Forward Voltage ²	I _F =3.0A CW	V _F	55	(60.5)	66	V
Beam Pointing Tilt Angle ³	I _F =3.0A CW	Δθ	Total Emission Area ⁴		1.1	°
Beam Divergence ⁴			Parallel	θ _{//}		
	Perpendicular	θ _⊥	-1.5	(0)	1.5	°

() are reference figures.

¹ Composed of 3 ranges.

² When connected in series with the 28 LD chips.

³ The beam pointing tilt angle measurement is performed for the total emission area once the LD initiates laser oscillation.

 To calculate the beam pointing tilt angle, the following equation is used: $\Delta\theta = \sqrt{\Delta\theta_{//}^2 + \Delta\theta_{\perp}^2}$
⁴ Full angle at 1/e² from peak intensity (Total Emission Area)

All figures in this specification are measured by Nichia's method and may contain measurement deviations.

The above specifications are for reference purpose only and subjected to change without prior notice.
NICHIA CORPORATION
<http://www.nichia.co.jp>
◆ HEADQUARTERS

491 Oka, Kaminaka-Cho, Anan-Shi, TOKUSHIMA 774-8601, JAPAN

PHONE: +81-884-22-2311 FAX: +81-884-21-0148

◆ CONTACT

TOKYO SALES OFFICE

13F Tamachi Center Building 34-7, Shiba 5-Chome, Minato-Ku, TOKYO 108-0014, JAPAN

PHONE: +81-3-3456-3746 FAX: +81-3-5440-7516

Outline Dimensions

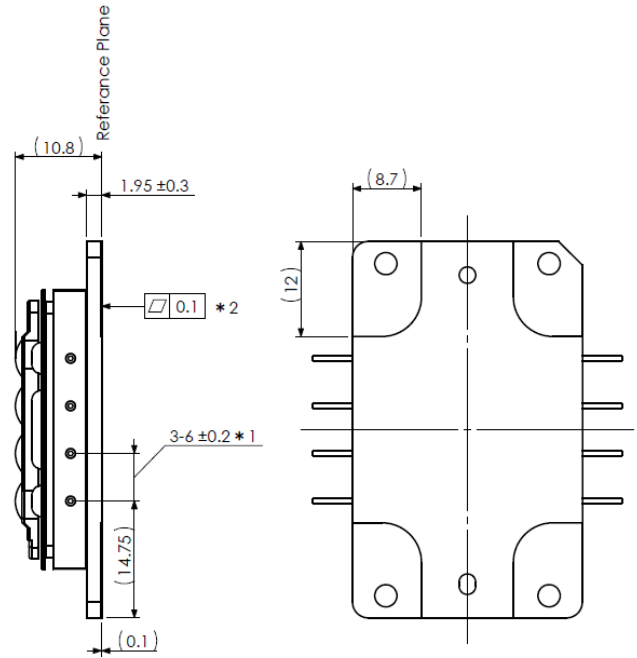
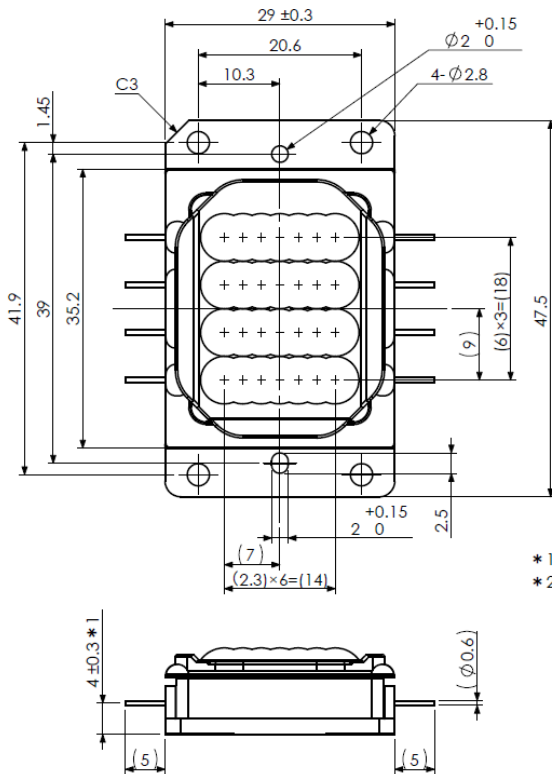

* 1: base of lead basic
 * 2: >70% area of bottom surface

※Note
 TOLERANCES based on JIS B 0405-m(Table), UNLESS NOTED

Table, Limits for Linear measures(mm)				
Range	0.5 to 3	above 3 to 6	above 6 to 30	above 30 to 120
Tolerance	±0.1	±0.1	±0.2	±0.3

Dimensions are in millimeters
 () are reference figures

LD chips Position No. & Pin Connection

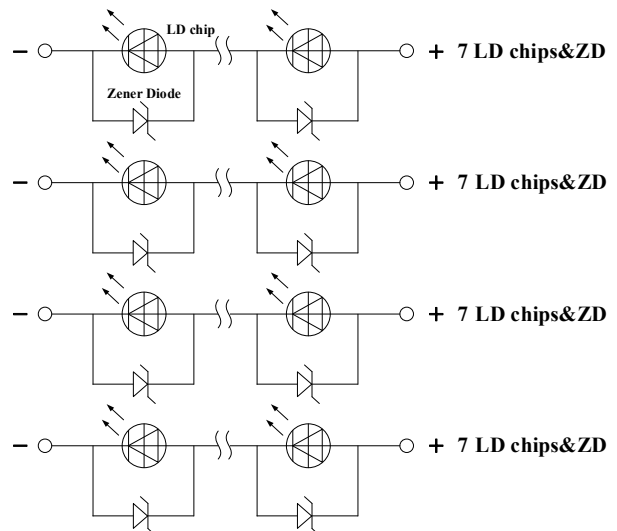
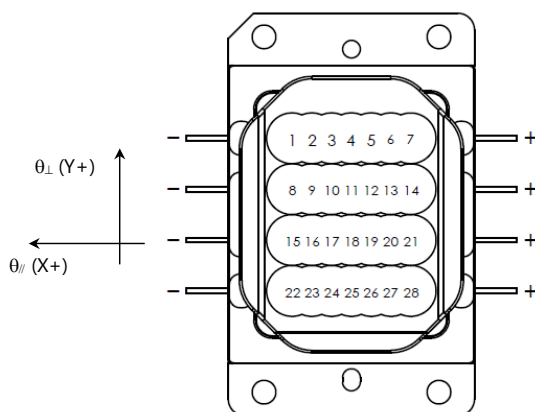

This model does not have a Photo Diode.
 This model has a Zener Diode built in as a protection circuit against static electricity.

■ Cautions

(1) Safety of Collimated beam LD

- **Laser Light can damage the human eyes and skin.** Do not expose the eye or skin to laser light directly. This Laser product has an optical lens and emits a collimated laser beam. The light from this product, both direct and reflected, is very harmful as it can propagate a long distance while maintaining high optical density. When handling the product, wear appropriate safety glasses to protect eyes from laser light including reflected and stray light. The reflected and stray light spilling into an unintended area should be attenuated and/or absorbed.
- The LD is classified in **Class 4 of IEC60825-1 and 21 CFR Part 1040.10 Safety Standards.** It is absolutely necessary to take overall safety measures against User's modules, equipment and systems into which Nichia LD is incorporated and/or integrated.



(2) Operating method

- The LD will change its forward voltage requirement and optical output power according to the temperature change. Also, the LD will require a higher operation current to maintain the same output power as it degrades. In order to maintain the output power, use of an APC (Automatic Power Control) is recommended, which uses feedback of the optical output power to adjust the operation current.
- Confirm that the electrical spike current generated by switching on and off does not exceed the maximum operating current as specified within this document as the absolute max rating. Additionally, ensure that there are appropriate countermeasures to reduce chattering and/or overshooting in the circuit.
- ACC (Auto Current Control) mode is recommended for the operation of this product. Additionally, be careful for the overshooting in order to avoid excessive optical output power as the laser operation is started.

(3) Design Consideration

- LDs may fail as either a short circuit or an open circuit. If an LD shorts during operation, the forward voltage of the LD may fluctuate greatly. When designing a circuit, ensure that both short and open circuits are considered and that there will be no issues if a short or open circuit occurs.
- Since this LD uses a resin to secure the lens, if the lens becomes removed during operation, it may cause unintentional laser exposure to occur (e.g. random radiation) leading to accidents/injuries (e.g. causing an object to smoke, fire, and the laser light to escape). Ensure that the chosen system includes a safeguard (e.g. containing the laser light, emergency shutdown, etc.).

(4) Static Electricity

- Static electricity or electrical surges will reduce and degrade the reliability of the LD. It is recommended to use a wrist strap or anti-electrostatic glove when handling the Product.

(5) Absolute Maximum Rating

- The active layer of the mounted LD chips has a high current density and generates a high electric field during its operation. In order to prevent excessive damage, the LD must be operated strictly below the Absolute Max Rating.
- During operation, if the forward current and/or optical output power are increased the lifetime of the LDs will decrease. Ensure that the LDs are operated within the recommended conditions.

(6) Others

- The LD described in this brochure is intended to be used for ordinary electronic equipment (such as office equipment, communications equipment, measurement instruments and household appliances). Consult Nichia's sales staff in advance for information on the applications in which exceptional quality and reliability are required, particularly when the failure or malfunction of the LD may directly jeopardize life or health (such as for airplanes, aerospace, submersible repeaters, nuclear reactor control systems, automobiles, traffic control equipment, life support systems and safety devices).
- The Purchaser must acknowledge that any LD can statistically fail and must design its equipment in a fail safe design. Prior to use of the LD, please confirm that the LD, as described in Nichia's specifications, meets the life expectancy needs of, and provides the features required by the Circuit and any related modules, equipment and/or systems.
- Due to its short wavelength and high optical output power, optical depositions on optical path may occur depending on the surrounding conditions. Appropriate design or countermeasures should be used to avoid optical depositions.
- Nichia prohibits Purchaser from reverse engineering, disassembling, or taking any other steps to derive the structure or design of the LD.
- The appearance and specifications of the product may be modified for improvement without notice. The formal specifications must be exchanged and signed by both parties before large volume purchase begins.
- No unauthorized transmission or reproduction of this document, either in whole or in part, is permitted.