

产品. 规格书

PRODUCT SPECIFICATION

产品名称

Product Name

1064激光器

产品编号

Product Number

LY43B20W-1064R2W-CL-T01

规格型号

Specification Model

140*85*73.4mm

东莞市蓝宇激光有限公司

Dongguan Blueuniverse Laser Co, Ltd

DESCRIPTION. :

(规格书)

SPECIFICATION

THESE SPECIFICATIONS ARE THE PROPERTY OF DONGGUAN BLUEUNIVERSE LASER CO., LTD. AND SHALL NOT BE REPRODUCED OR USED AS THE BASIS FOR THE MANUFACTURE OR SELL OF APPARATUSES OR DEVICES WITHOUT PERMISSION.

Model No. :

LY43B20W-1064R2W-CL-T01

日期

制定

品管

审核

核准

Document No. :

LY-WI-RD-F3958

REV

A0

1064 产品参数

PRODUCT PARAMETERS

项目 Items	参数 Parameter	项目 Items	参数 Parameter
结构尺寸: Housing size	140*85*73.4mm	透镜: Optical Lens	Glass
电路板尺寸: Circuit Board Size	/	散热形式: Form of heat dissipation	TEC
电路板: Circuit Board	24V	主体材质: Body material	Aluminum
线材: Wire Rod	/	产品净重: Product Net Weight	/

1064 光电参数

OPTICAL PARAMETERS

TC=25℃

项目 Items	符号 Symbol	最小 Min	标准 Typ	最大 Max	单位 Unit	条件 Condition
光输出功率: Optical Output Power	Po	1.5	/	/	W	Duty Cycle: 100%
工作电流: Working current	Iop	/	1.7	2	A	
工作电压: Operating Voltage	Vop	/	24	/	V	
激光波长: Laser Wavelength	λ_p	/	1064	/	nm	
电功率: Electric Power	W1	/	40.8	48	W	

控制信号电压: Control signal voltage	3.3V	控制方式: The control mode	PWM Modulation
响应频率: Response frequency	<5KHz	起始响应占空比: Initial response duty	/
光斑模式: Laser Beam Mode	Dot	工作模式: Working Mode	Pulse work
焦距: The focal length	220±1mm	工作温度: Working Temperature	20℃`36℃
焦点大小: The focus size	/	储存温度: Storage Temperature	-20℃~60℃
工作时间: Working Time	10000H	外壳带电极性: Enclosure Polarity	No Connected

450 产品参数

PRODUCT PARAMETERS

项目 Items	参数 Parameter	项目 Items	参数 Parameter
结构尺寸: Housing size	140*85*73.4mm	透镜: Optical Lens	Glass
电路板尺寸: Circuit Board Size	/	散热形式: Form of heat dissipation	Air Cooling
电路板: Circuit Board	24V	主体材质: Body material	Aluminum
线材: Wire Rod	/	产品净重: Product Net Weight	/

450 光电参数

OPTICAL PARAMETERS

TC=25℃

项目 Items	符号 Symbol	最小 Min	标准 Typ	最大 Max	单位 Unit	条件 Condition
光输出功率: Optical Output Power	Po	18	/	/	W	Duty Cycle: 100%
工作电流: Working current	Iop	/	3	3.2	A	
工作电压: Operating Voltage	Vop	/	24	/	V	
激光波长: Laser Wavelength	λ_p	425	435	445	nm	
电功率: Electric Power	W1	/	72	76.8	W	

控制信号电压: Control signal voltage	3.3V	控制方式: The control mode	PWM Modulation
响应频率: Response frequency	<5KHz	起始响应占空比: Initial response duty	/
光斑模式: Laser Beam Mode	Dot	工作模式: Working Mode	Pulse work
焦距: The focal length	220±1mm	工作温度: Working Temperature	20℃-36℃
焦点大小: The focus size	<400*220um	储存温度: Storage Temperature	-20℃-60℃
工作时间: Working Time	10000H	外壳带电极性: Enclosure Polarity	No Connected

外形尺寸

DIMENSIONS

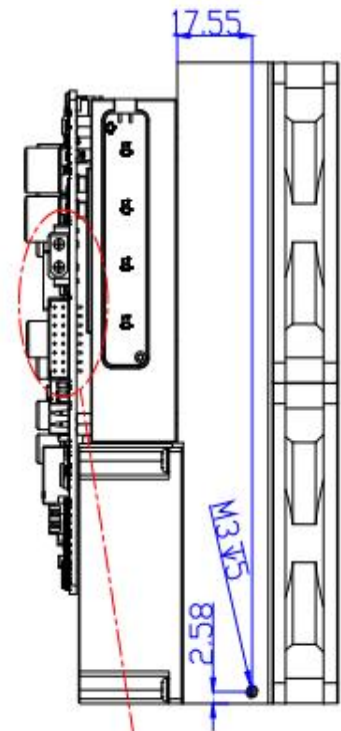
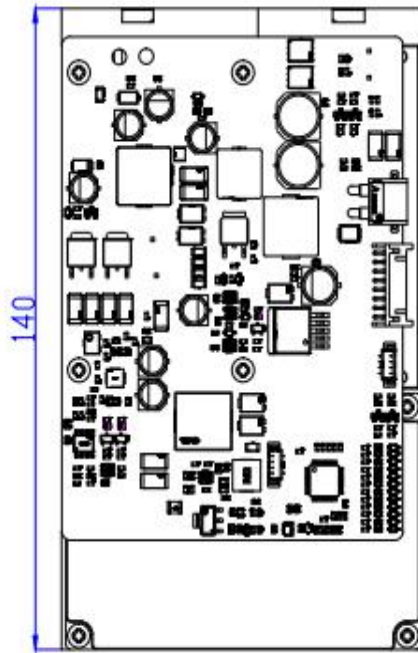
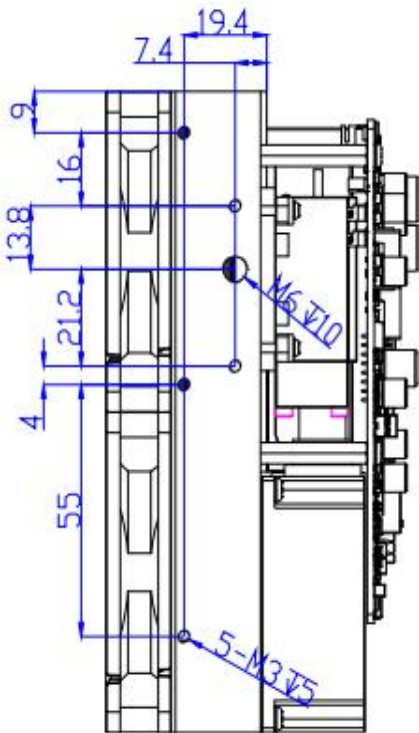
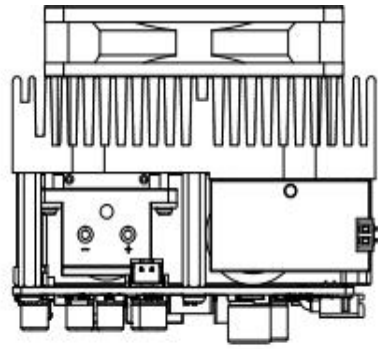

UNSPECIFIED DIMENSIND TOL(GB/T1804-92)

DIM	TOL	COARSENESS
0.5~3		±0.02
3~6		±0.05
6~30		±0.1
30~120		±0.2
120~400		±0.5

UNSPECIFIED ANGLE TOL(GB11359-89-M) ±1°

Form No: FR-04-0013 Revision: REV0 Date:2016-4-11

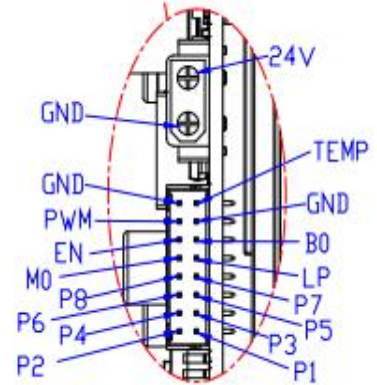
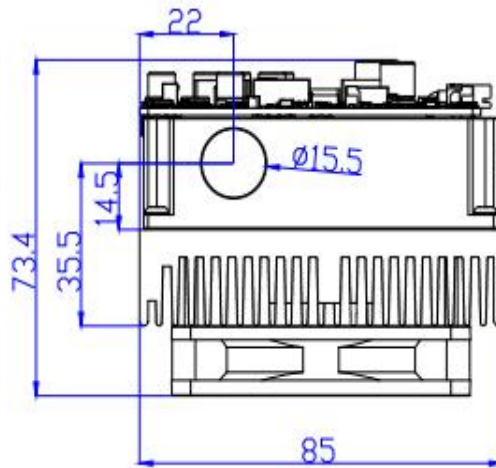

引脚定义

引脚号	信号名称	说 明
1	DB25_P1	激光器功率控制信号 P1。TTL 输入，高电平有效
2	DB25_P2	激光器功率控制信号 P2。TTL 输入，高电平有效
3	DB25_P3	激光器功率控制信号 P3。TTL 输入，高电平有效
4	DB25_P4	激光器功率控制信号 P4。TTL 输入，高电平有效
5	DB25_P5	激光器功率控制信号 P5。TTL 输入，高电平有效
6	DB25_P6	激光器功率控制信号 P6。TTL 输入，高电平有效
7	DB25_P7	激光器功率控制信号 P7。TTL 输入，高电平有效
8	DB25_P8	激光器功率控制信号 P8。TTL 输入，高电平有效
9	DB25_P22	激光器预览光开关信号。TTL 输入，高电平有效
10	DB25_P18	主振荡器 (M0) 开关信号。TTL 输入，高电平有效
11	DB25_P19	放大器 (B0) 开关信号。TTL 输入，高电平有效
12	DB25_PBL	蓝光/激光选择开关信号。TTL 输入，高电平蓝光开， 低电平 1064nm 激光开

PWM 风扇控制信号 TEMP 温度检测 G=地

注 意 事 项

CAUTIONS

1. 激光模组发射的激光有可能对眼睛造成伤害。激光模组工作时，严禁直接注视其端面，并佩戴防护眼镜。

The laser light emitted by the laser module is likely to injure persons' eye, so do not directly gaze its end surface and wear appropriate safety glasses to prevent laser light when it is working.

2. 器件需要合适的驱动电源，激光模组和电源连接时，电源输出电压应为零；电流调节时应缓慢增加或减少，以免冲击电流损坏器件。

Laser module needs an appropriate laser driver(PCB). When the laser module connects with power supply, please set the output voltage to zero. The adjustment of the current should be slowly increased or decrease to avoid damaging the device.

3. 器件应当存放或工作于干燥环境，防尘等级达到百万级，已免镜片落入灰尘影响光斑。

Keep the device working or storing in a dry environment. The anti-dust grade is over one million, in order to prevent dust inside the lens to affect the laser dot shape.

4. 在较高温度下工作，会增大阈值电流，降低转换效率，加速器件的老化。

Working at high temperatures will increase the threshold current, reduce conversion efficiency and speed up the aging of the device.

5. 输出功率高于指定参数工作，会加速器件老化。

When output power is higher than it's specific parameter of operation, it will accelerate the aging of the device.

6. 连续工作中激光管温度达到36℃要做好散热。

When the operation temperature of the laser diode is over 36degree, please do well heat dissipation of it.

7. 本产品属于静电敏感器件，在人体有良好接地的情况下才可拿取，防静电可采用防静电手镯的方法。

This laser module is an electrostatic sensitive device. Please make sure ground yourself or wear an antistatic wrist strap before you take it.



Dongguan Blueuniverse Laser
Co.,Ltd
400-7777-956
<http://www.bu-laser.Com>

东莞市蓝宇激光有限公司

Dongguan Blueuniverse Laser Co.,Ltd

DESCRIPTION.:

(规格书)

SPECIFICATION

THESE SPECIFICATIONS ARE THE PROPERTY OF DONGGUAN BLUEUNIVERSE LASER CO.,LTD. AND SHALL NOT BE REPRODUCED OR USED AS THE BASIS FOR THE MANUFACTURE OR SELL OF APPARATUSES OR DEVICES WITHOUT PERMISSION.

Model No.:

LY43B20W-1064R2W-CL-T01

Document No.:

LY-WI-RD-F3958

REV

A0